

Installing 100 Watt Speakers ES100C and ES100C-DEU

⚠ WARNING

Safety Message to Installers

People's lives depend on your proper installation and servicing of Federal Signal products. It is important to read and follow all instructions shipped with this product and the original product. Listed below are some other important safety instructions and precautions you should follow:

Before Installation

Qualifications

- To properly install an electronic siren, you must have a good understanding of automotive electrical procedures and systems, along with proficiency in the installation and service of safety warning equipment. Always refer to the vehicle service manuals when installing equipment on a vehicle.

Sound Hazards

- Your hearing and the hearing of others, in or near your emergency vehicle, could be damaged by loud sounds. This can occur from short exposures to very loud sounds, or from longer exposures to moderately loud sounds. For hearing conservation guidance, refer to federal, state, or local recommendations. OSHA Standard 1910.95 offers guidance on "Permissible Noise Exposure."
- All effective sirens and horns produce loud sounds (120 dB) that may cause permanent hearing loss. Always minimize your exposure to siren sound and wear hearing protection. Do not sound the siren indoors or in enclosed areas where you and others will be exposed to the sound.
- Federal Signal siren amplifiers and speakers are designed to work together as a system. Combining a siren and speaker from different manufacturers may reduce the warning effectiveness of the siren system and may damage the components. You should verify or test your combination to make sure the system works together properly and meets federal, state, and local standards or guidelines.

During Installation

- DO NOT get metal shavings inside the product. Metal shavings can cause the system to fail. If drilling must be done near the unit, place an ESD-approved cover over the unit to prevent metal shavings from entering the unit. Inspect the unit after mounting to be sure there are no shavings present in or near the unit.

- DO NOT connect this system to the vehicle battery until ALL other electrical connections are made, mounting of all components is complete, and you have verified that no shorts exist. If wiring is shorted to vehicle frame, high current conductors can cause hazardous sparks resulting in electrical fires or flying molten metal.
- Be sure the siren amplifier and speaker(s) in your installation have compatible wattage ratings.
- In order for the electronic siren to function properly, the ground connection must be made to the NEGATIVE battery terminal.
- Sound output will be severely reduced if any objects are in front of the speaker. If maximum sound output is required for your application, you should ensure that the front of the speaker is clear of any obstructions.
- Install the speaker(s) as far forward on the vehicle as possible, in a location that provides maximum signaling effectiveness while minimizing the sound reaching the vehicle's occupants. Refer to the National Institute of Justice Guide 500-00 for further information.
- Mounting the speakers behind the grille will reduce the sound output and warning effectiveness of the siren system. Before mounting speakers behind the grille, make sure the vehicle operators are trained and understand that this type of installation is less effective for warning others.
- Sound propagation and warning effectiveness will be severely reduced if the speaker is not facing forward. Carefully follow the installation instructions and always install the speaker with the projector facing forward.
- DO NOT install the speaker(s) or route the speaker wires where they may interfere with the operation of airbag sensors.
- Installation of two speakers requires that you wire the speakers in phase.
- Never attempt to install aftermarket equipment, which connects to the vehicle wiring, without reviewing a vehicle wiring diagram, which is available from the vehicle manufacturer. Insure that your installation will not affect vehicle operation and safety functions or circuits. Always check vehicle for proper operation after installation.
- DO NOT install equipment or route wiring or cord in the deployment path of an airbag.
- Locate the control head so the vehicle, controls, and microphone can be operated safely.
- When drilling into a vehicle structure, be sure that both sides of the surface are clear of anything that could be damaged.

After Installation

- After installation, test the siren system and light system to ensure that it is operating properly.
- Test all vehicle functions, including horn operation, vehicle safety functions and vehicle light systems, to ensure proper operation. Ensure that installation has not affected vehicle operation or changed any vehicle safety function or circuit.
- CAUTION: HOT SURFACE — The speaker gets hot enough to burn you. Always allow it to cool before handling it.**
- After testing is complete, provide a copy of these instructions to the instructional staff and all operating personnel.
- File these instructions in a safe place and refer to them when maintaining and/or reinstalling the product.

Failure to follow all safety precautions and instructions may result in property damage, serious injury, or death.

Unpacking the Product

After unpacking the product, inspect it for damage that may have occurred in transit. If it has been damaged, do not install it. File a claim immediately with the carrier, stating the extent of damage. Carefully check all envelopes, shipping labels, and tags before removing or destroying them.

Mounting the Speaker

⚠ WARNING

ES100C SERIES SPEAKER WIRES: To avoid reducing the sound output and damaging the speaker, ensure that the speaker is mounted with the wires protruding from the bottom of the speaker.

⚠ WARNING

SOUND REDUCTION WARNING: To avoid reduction of sound output, ensure that the speaker is mounted with the sound opening facing directly in the direction intended to warn.

NOTICE

DRILLING PRECAUTIONS: Before drilling holes, check the area into which you plan to drill to ensure you do not damage vehicle components while drilling. All drilled holes should be deburred and all sharp edges should be smoothed. All wires going through drilled holes should be protected by a grommet or convolute/split-loom tubing.

NOTICE

THREAD DAMAGE AND GALLING: To prevent thread damage and galling, anti-seize lubricant must be used on all stainless steel fasteners.

Select an appropriate mounting location that provides both adequate support and sufficient clearance for the speaker assembly. In addition, the mounting location should provide maximum signaling effectiveness while minimizing the sound reaching the vehicle's occupants.

The ES100C Series speakers are compact speakers intended to be mounted with a separately purchased Federal Signal mounting system. If the speakers are installed with another mounting system, the safety and effectiveness of the installation must be carefully evaluated. Refer to the mounting instructions included with the speaker mounting system.

Figure 1 Speaker dimensions

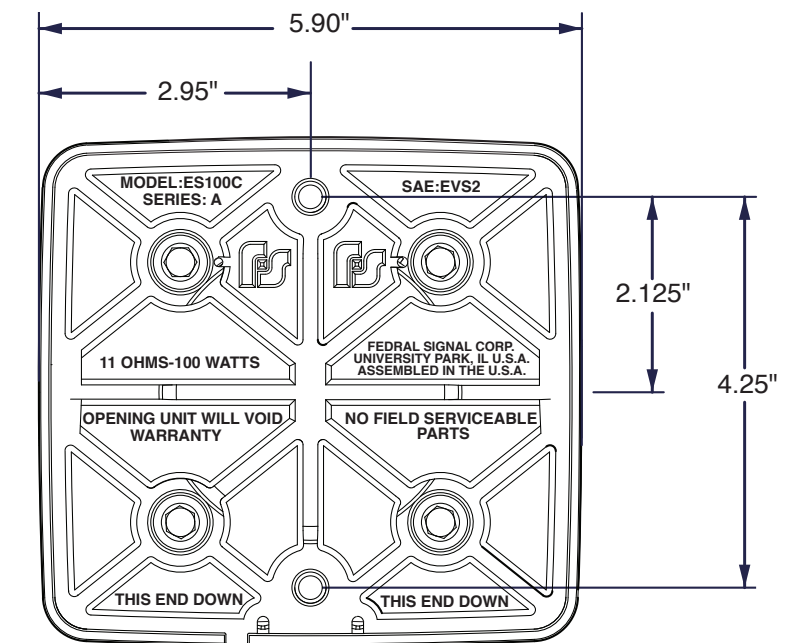

Surface Mounting without the Bracket

NOTE: Because of the variety of vehicles and possible mounting arrangements, installation details and mounting bracket fabrication must be determined by the installer.

The speaker can be mounted on a flat surface with user-supplied 5/16" stainless-steel bolts. Choose bolts of the correct length to ensure that the speaker does not move.

To mount the speaker:

- Select a mounting surface that is flat and supports the speaker.
- Use the speaker's back plate as a template to mark the centers of the mounting holes.
- Drill two 5/16" holes.
- Secure the speaker with two 5/16" stainless-steel bolts.

Wiring the Speaker

IMPORTANT: The ES100C Series speakers comply with the requirements of SAE J1849 EVS2 and CCR Title 13 Class A when they are used with Federal Signal Corporation electronic sirens. The ES100C Series speaker includes the two models describe below.

ES100C (18 AWG tinned wire leads)

See Figure 1 on the other side. Connect the black ground lead (#1) and white power lead (#2) from the speaker to the speaker cable from the electronic siren. Refer to the instructions included with the electronic siren for details.

ES100C-DEU (Deutsch connector)

See Figure 2 on the other side. Connect the Deutsch connector from the speaker to the Deutsch connector from the electronic siren so that pin positions 1 and 2 of the connectors match. The numbers of the pin positions are on the side of the connector housings.

Figure 2 Model ES100C

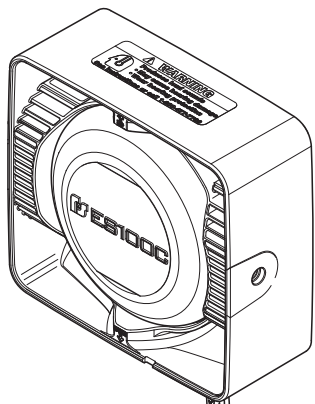
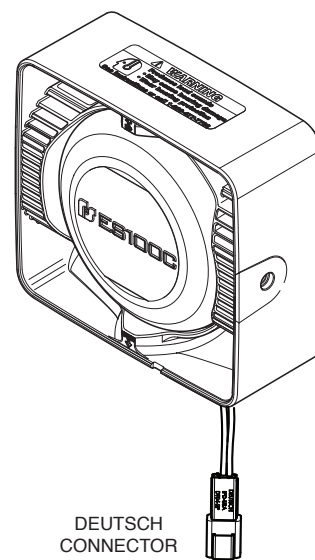

Figure 3 Model ES100C-DEU



Testing the Siren System

⚠ WARNING

SOUND HAZARD: All effective sirens and horns produce loud sounds (120 dB) that may cause permanent hearing loss. Always minimize your exposure to siren sound and wear hearing protection. Do not sound the siren indoors or in enclosed areas where you and others will be exposed to the sound.

After the installation, test the siren system to ensure that it is operating properly. Also test all vehicle functions, including horn operation, vehicle safety functions, and vehicle lighting systems to insure proper operation. Ensure that the installation has not affected the vehicle operation or changed any vehicle safety functions or circuits.

Do not test the sound and light system of the vehicle while driving. Operating the vehicle warning systems may pose a hazard to the operator and other drivers if the systems do not function as expected. Test the vehicle only in a controlled environment.

Safety Message to Operators

⚠ WARNING

People's lives depend on your safe operation of Federal products. It is important to read and follow all instructions shipped with the products. In addition, listed below are some other important safety instructions and precautions you should follow:

Qualifications

- To properly use an electronic siren and speaker(s), you must have a good understanding of general vehicle operation, a high proficiency in the use of safety warning equipment, and thorough knowledge of state and federal UNIFORM TRAFFIC CODES.

Sound Hazard

- Your hearing and the hearing of others, in or close to your emergency vehicle, could be damaged by loud sounds. This can occur from short exposures to very loud sounds, or from longer exposures to moderately loud sounds. For hearing conservation guidance, refer to federal, state, or local recommendations. OSHA Standard 1910.95 offers guidance on "Permissible Noise Exposure."
- All effective sirens and horns produce loud sounds (120 dB) that may cause permanent hearing loss. Always minimize your exposure to siren sound, roll up your windows and wear hearing protection. Do not sound the siren indoors or in enclosed areas where you and others will be exposed to the sound. Only use the siren for emergency response situations.

Sound Limitations

- Before using the vehicle, check to see if the siren speakers are concealed from view. If the siren speaker is not in clear view on the front of the vehicle, use extra caution when operating the vehicle. A concealed siren speaker installation is less effective at warning others.
- Maximum sound output will be severely reduced if any objects are in front of the speaker. If your installation has obstructions in front of the speaker, drive even more cautiously. Make sure you allow enough time for the speaker to cool.
- Frequently inspect the speaker to ensure that it is clear of any obstruction, such as mud or snow, which will reduce maximum sound output.

Signaling Limitations

- Be aware that the use of your visual and audible signaling devices does not give you the right to force your way through traffic. Your emergency lights, siren, and actions are REQUESTING the right-of-way.
- Although your warning system is operating properly, it may not alert everyone. People may not hear, see, or heed your warning signal. You must recognize this fact and continue driving cautiously.
- Situations may occur which obstruct your warning signal when natural or man-made objects are between your vehicle and others. This can also occur when you raise your hood or trunk lid. If these situations occur, be especially careful.

Driving Limitations

- At the start of your shift, you should ensure that the light/sound system is securely attached to the vehicle and operating properly.
- If the unique combination of emergency vehicle equipment installed in your vehicle has resulted in the siren controls being installed in a position that does not allow you to operate them by touch only. OPERATE CONTROLS ONLY WHILE YOUR VEHICLE IS STOPPED.
- If driving conditions require your full attention, you should avoid operating the siren controls while the vehicle is in motion.

Continuing Education

- File these instructions in a safe place and refer to them periodically. Give a copy of these instructions to new recruits and trainees.

Failure to follow these safety precautions may result in property damage, serious injury, or death to you, to passengers, or to others. For operation instructions, refer to the instructions included with the electronic siren.

Getting Technical Support

If you are experiencing problems with the speaker, contact:

Service Department
Federal Signal Corporation
Phone: 1-800-433-9132
Fax: 1-800-343-9706
Email: empSERVICEINFO@fedSIG.COM

Returning a Product to Federal Signal

This speaker has no field-serviceable parts. The Federal Signal factory can and will service your speaker. Any product returned to Federal Signal for service, inspection, or repair must be accompanied by a Return Material Authorization number. Obtain a RMA number from a local distributor or Federal Signal. (Call Federal Signal at 800-264-3578, 800-433-9132 or 800-824-0254.)

Provide a brief explanation of the service requested or the nature of the malfunction and the following:

- Your Federal Signal customer or account number.
- The purchase order number under which the items were purchased.
- The shipping method.
- The model or part number of the product being returned.
- The quantity of products being returned.
- Drop ship information as needed.
- Any estimate required.

When you receive your RMA Number:

- Write the RMA number on the outside of the box of returned items.
- Reference the RMA number on your paperwork inside of the box.
- Write the RMA number down so that you can easily check on status of the returned equipment.

Send all material with the issued RMA Number to the following:

Federal Signal Corporation
2645 Federal Signal Drive
University Park, IL 60484-3167
Attn: Service Department
RMA: # _____

www.fedSIG.COM